



High Amperage — 25 to 200 AMP
Type I & III Vehicle Protection
IP67 & IP69K Waterproof
Ignition-Protected
SAE & ABYC Compliant



Series 19

Raising the Bar
MP—Count on it

Series 19



Series 19 Overview

The Series 19 features:

- Wider Amperage Range - 25 to 200 Amp
- Smallest Available Breaker to 200 Amp
- Superior Ingress Protection—IP67 & IP69K
- Designed for Harsh Applications to 30VDC
- New LED *tripID*TM for Open Circuits
- Recognized per UL1077 (pending)
- Type I and Type III Manual Reset

Series 19 Specifications

Standard Amp Ratings

The Series 19 is available in ratings of 25, 30, 35, 40, 45, 50, 60, 70, 80, 90, 100, 105, 120, 135, 150, **175 and 200** amps.

Maximum Voltage Ratings

30 VDC

Ultimate Trip

Must Hold 100% at 25°C/77°F.

Must Trip at 135% within 1 hour.

Dielectric Strength

1,500VAC Minimum

Interrupt Capacity (25 - 150A), up to

2,500A @ 14VDC (Type III)

1,500A @ 28VDC (Type III)

2,500A @ 30VDC (Type I)

Interrupt Capacity (175 - 200A)

2,500A @ 30VDC (Type I and Type III)

Endurance (25 - 150A)

14VDC @ 100 cycles, 6X rating (Type I & Type III)

28VDC @ 100 cycles, 2X rating (Type III)

30VDC @ 100 cycles, 2X rating (Type I)

Endurance (175 - 200A)

14VDC @ 100 cycles, 6X rating (Type I)

14VDC @ 100 cycles, 2X rating (Type III)

28VDC @ 50 cycles, 2X rating (Type III)

30VDC @ 100 cycles, 2X rating (Type I)

Typical Overload Trip Time Data (in seconds)

Current Rating	200%	400%	600%	800 %	1000%
25-200 Amps	10-40	0.6-7.0	0.2-3.0	0.15- 2.0	0.09-1.2

Typical Ambient Temperature Correction Factor

Current Rating	°F	-40	0	50	77	150	200
	°C	-40	-18	10	25	65	93
25-200 Amps		0.80	0.84	0.87	1.00	1.22	1.47

Specifications Subject To Change

Single Pole Thermal Circuit Breakers



Type III Manual Reset w/New LED *tripID*TM, Wide Mounting Plate and Attached Mounting Nuts
Shown: Part Number 19M-P21-R-200-02

Operating Temperature Range

-40°C/-40°F to 85°C/185°F

Weight

Panel Mount: 2.6 oz. (74 gm.)

Panel Mount w/Plate: 5.0 oz. (140 gm.)

Environmental

Ignition Protected

Compliant to SAE J1171

Ingress Protection

IP67 - dust and waterproof rated.

IP69K - high temperature and pressure spray

Corrosion

Conforms to Mil-STD-202, Method 101, Test Condition A, for 96 hours under a 5% salt spray.

Humidity

Conforms to Mil-STD-202, Method 106, for 240 hours at 95% RH.

Shock

Rated to withstand 100g per Mil-STD-202, Method 213, Test Condition A.

Vibration

Rated to withstand 10g per Mil-STD-204, Test Condition A.

Regulatory Compliance Summary

Interrupt Capacity: SAE J1625, ABYC-E11, UL1077*

Ignition Protected: SAE J1171

Endurance: SAE J1625

Dielectric Strength: UL1077*

Shock, Vibration, Corrosion, Humidity: Mil-STD-202

Dust and Waterproof: IP67

High Temp & Pressure Spray: IP69K

*tested per UL1077 methods

**Mechanical
Products
Company**

1112 N. Garfield
Lombard, Illinois 60148
phone 630 | 953 | 4100
fax 630 | 953 | 4110
www.mechprod.com
helpme@mechprod.com



19A-P10

Type I Auto Reset Panel Mount

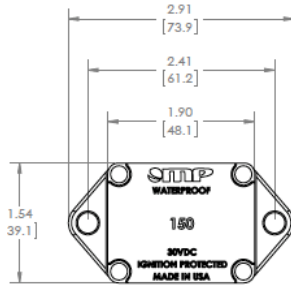

19A-P11

Type I Auto Reset Panel Mount with LED *tripID*™ and Attached Self Lock Mounting Nuts

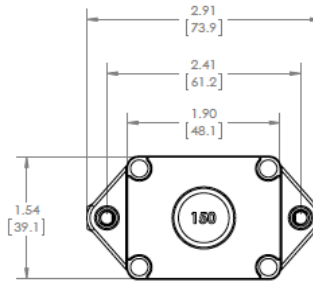

19M-P10

Type III Manual Reset Panel Mount

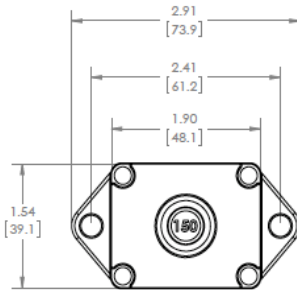

19M-P11

Type III Manual Reset Panel Mount with Attached Self Lock Mounting Nuts

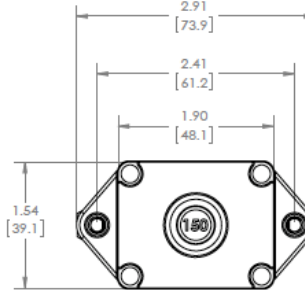

19M-P21

Type III Manual Reset Panel Mount with Wide Mounting Plate and Attached Mounting Nuts

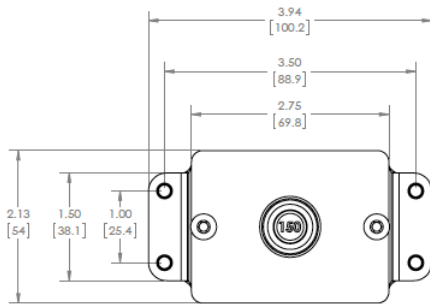

Type III Manual Reset - Side View

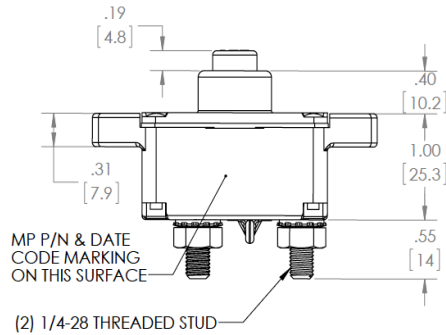

Rear Mount Panel Cutout Dimensions Without Wide Mounting Plate

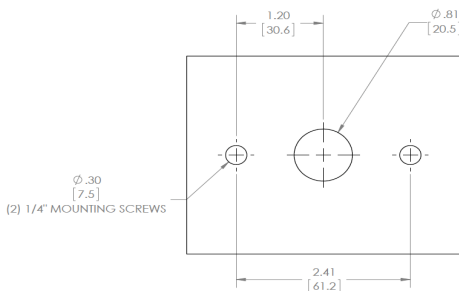

Front Mount Panel Cutout Dimensions Without Wide Mounting Plate

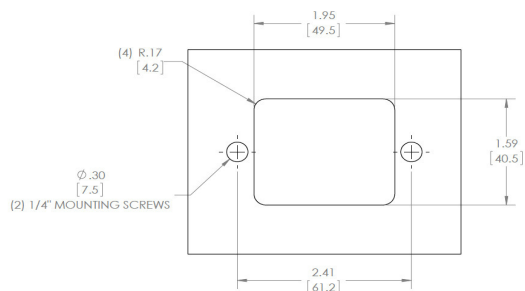

Series 19 Typical Trip Curve

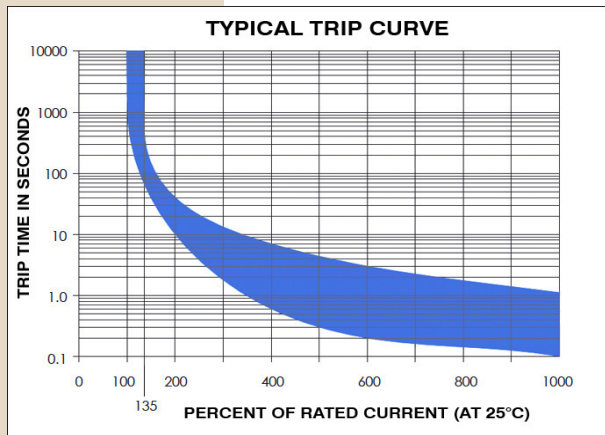

Series 19 Derating Curve

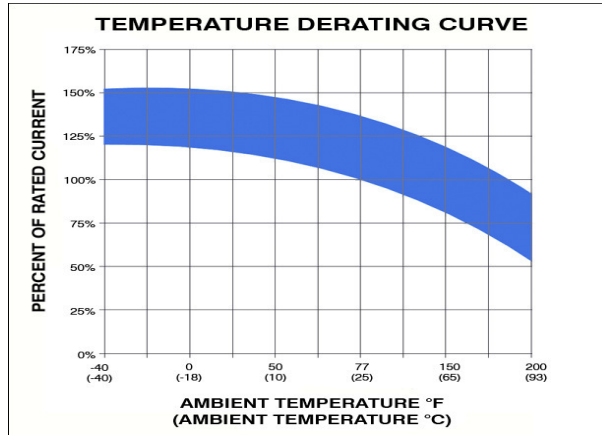

Series 19 Typical High Amp Applications

- Heavy Trucks
- Motorhomes
- Marine
- Battery Chargers
- Wheelchair Lifts
- Construction
- Buses
- Earth-moving Equipment
- Harsh Environments
- Engine Compartments
- Mining Equipment
- Military



Type I Auto Reset w/New LED *tripID™*
Shown: Part Number 19A-P10-C-150-02

Series 19 Part Numbering Guide

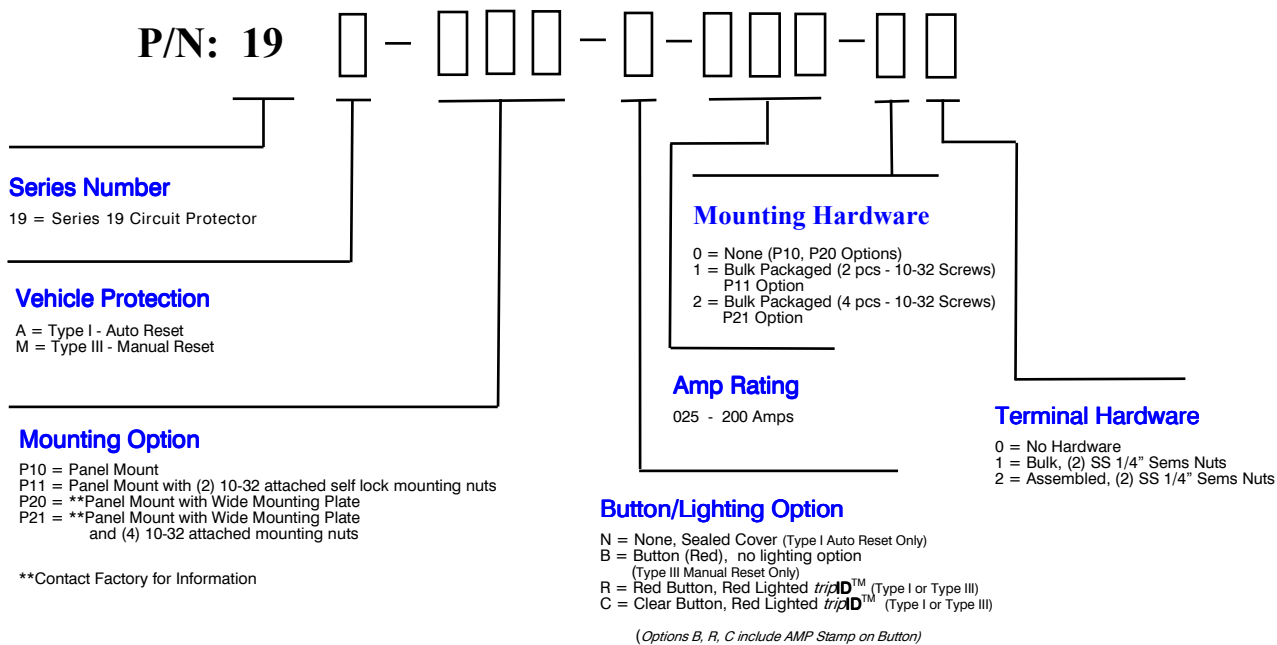

Mechanical Products Company

1112 N. Garfield
Lombard, Illinois 60148
phone 630 | 953 | 4100
fax 630 | 953 | 4110
www.mechprod.com
helpme@mechprod.com





High Amperage — 25 to 200 AMP
Type I & III Vehicle Protection
IP67 & IP69K Waterproof
Ignition-Protected
SAE & ABYC Compliant



Series 19

Raising the Bar
MP—Count on it



Series 19 Overview

The Series 19 features:

- Wider Amperage Range - 25 to 200 Amp
- Smallest Available Breaker to 200 Amp
- Superior Ingress Protection—IP67 & IP69K
- Designed for Harsh Applications to 30VDC
- New LED *tripID*TM for Open Circuits
- Recognized per UL1077 (pending)
- Type I and Type III Manual Reset

Series 19 Specifications

Standard Amp Ratings

The Series 19 is available in ratings of 25, 30, 35, 40, 45, 50, 60, 70, 80, 90, 100, 105, 120, 135, 150, **175 and 200** amps.

Maximum Voltage Ratings

30 VDC

Ultimate Trip

Must Hold 100% at 25°C/77°F.

Must Trip at 135% within 1 hour.

Dielectric Strength

1,500VAC Minimum

Interrupt Capacity (25 - 150A), up to

2,500A @ 14VDC (Type III)

1,500A @ 28VDC (Type III)

2,500A @ 30VDC (Type I)

Interrupt Capacity (175 - 200A)

2,500A @ 30VDC (Type I and Type III)

Endurance (25 - 150A)

14VDC @ 100 cycles, 6X rating (Type I & Type III)

28VDC @ 100 cycles, 2X rating (Type III)

30VDC @ 100 cycles, 2X rating (Type I)

Endurance (175 - 200A)

14VDC @ 100 cycles, 6X rating (Type I)

14VDC @ 100 cycles, 2X rating (Type III)

28VDC @ 50 cycles, 2X rating (Type III)

30VDC @ 100 cycles, 2X rating (Type I)

Typical Overload Trip Time Data (in seconds)

Current Rating	200%	400%	600%	800 %	1000%
25-200 Amps	10-40	0.6-7.0	0.2-3.0	0.15- 2.0	0.09-1.2

Typical Ambient Temperature Correction Factor

Current Rating	°F	-40	0	50	77	150	200
	°C	-40	-18	10	25	65	93
25-200 Amps		0.80	0.84	0.87	1.00	1.22	1.47

Specifications Subject To Change

Single Pole Thermal Circuit Breakers



Type III Manual Reset w/New LED *tripID*TM, Wide Mounting Plate and Attached Mounting Nuts
Shown: Part Number 19M-P21-R-200-02

Operating Temperature Range

-40°C/-40°F to 85°C/185°F

Weight

Panel Mount: 2.6 oz. (74 gm.)

Panel Mount w/Plate: 5.0 oz. (140 gm.)

Environmental

Ignition Protected

Compliant to SAE J1171

Ingress Protection

IP67 - dust and waterproof rated.

IP69K - high temperature and pressure spray

Corrosion

Conforms to Mil-STD-202, Method 101, Test Condition A, for 96 hours under a 5% salt spray.

Humidity

Conforms to Mil-STD-202, Method 106, for 240 hours at 95% RH.

Shock

Rated to withstand 100g per Mil-STD-202, Method 213, Test Condition A.

Vibration

Rated to withstand 10g per Mil-STD-204, Test Condition A.

Regulatory Compliance Summary

Interrupt Capacity: SAE J1625, ABYC-E11, UL1077*

Ignition Protected: SAE J1171

Endurance: SAE J1625

Dielectric Strength: UL1077*

Shock, Vibration, Corrosion, Humidity: Mil-STD-202

Dust and Waterproof: IP67

High Temp & Pressure Spray: IP69K

*tested per UL1077 methods

**Mechanical
Products
Company**

1112 N. Garfield
Lombard, Illinois 60148
phone 630 | 953 | 4100
fax 630 | 953 | 4110
www.mechprod.com
helpme@mechprod.com



19A-P10

Type I Auto Reset Panel Mount

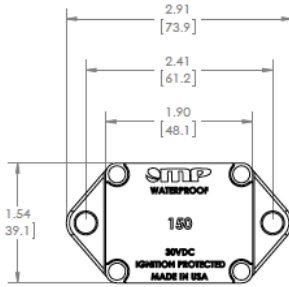

19A-P11

Type I Auto Reset Panel Mount with LED *tripID*™ and Attached Self Lock Mounting Nuts

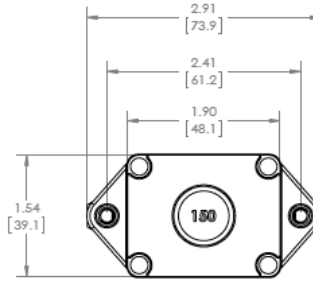

19M-P10

Type III Manual Reset Panel Mount

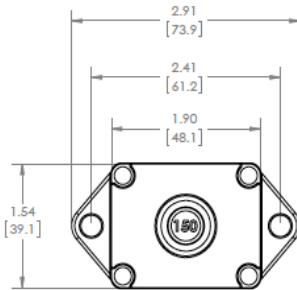

19M-P11

Type III Manual Reset Panel Mount with Attached Self Lock Mounting Nuts

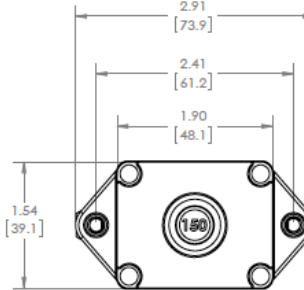

19M-P21

Type III Manual Reset Panel Mount with Wide Mounting Plate and Attached Mounting Nuts

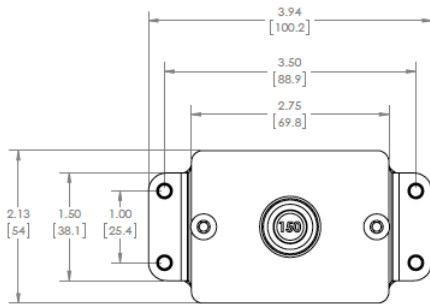

Type III Manual Reset - Side View

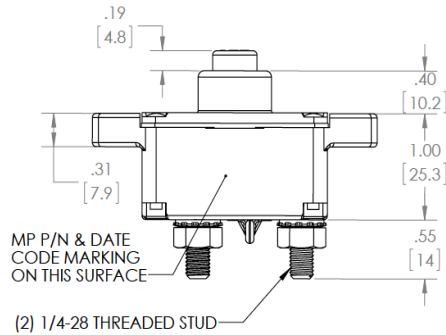

Rear Mount Panel Cutout Dimensions Without Wide Mounting Plate

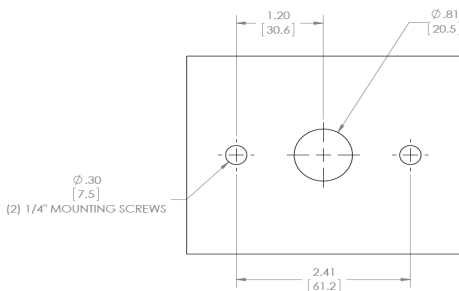

Front Mount Panel Cutout Dimensions Without Wide Mounting Plate

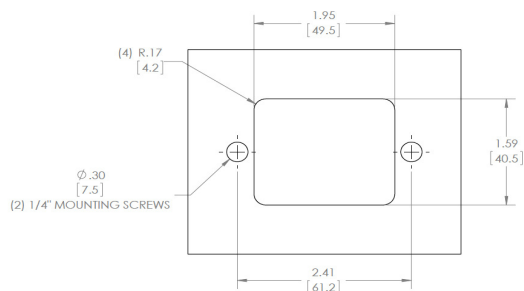

Series 19 Typical Trip Curve

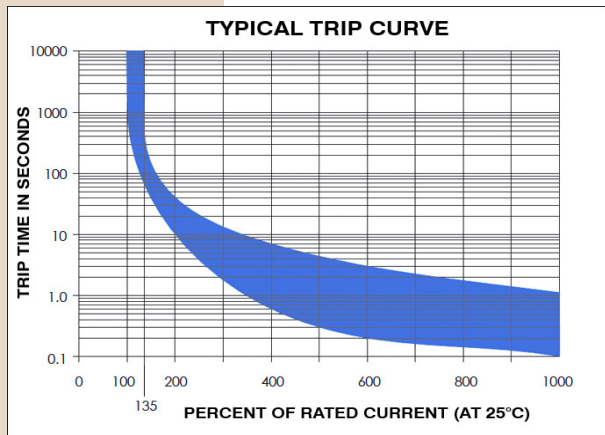

Series 19 Derating Curve

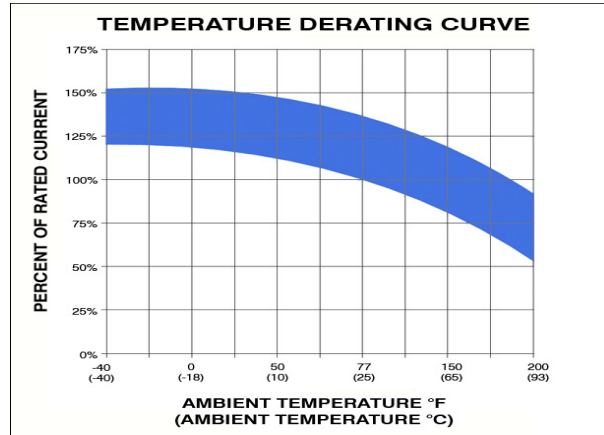

Series 19 Typical High Amp Applications

- Heavy Trucks
- Motorhomes
- Marine
- Battery Chargers
- Wheelchair Lifts
- Construction
- Buses
- Earth-moving Equipment
- Harsh Environments
- Engine Compartments
- Mining Equipment
- Military



Type I Auto Reset w/New LED *tripID™*
Shown: Part Number 19A-P10-C-150-02

Series 19 Part Numbering Guide

